

USER GUIDE

GUIDE D'UTILISATION

Gas cooktop
Surface de cuisson

CG244D, CG305D & CG365D models

Modèles de série

CG244D, CG305D et CG365D

US CA

Fisher & Paykel

⚠ WARNING!

If the information in this manual is not followed exactly, a fire or explosion may result causing property damage, personal injury or death.

Do not store or use gasoline or other flammable vapors and liquids in the vicinity of this or any other appliance.

NEVER use this appliance as a space heater to heat or warm the room. Doing so may result in carbon monoxide poisoning and overheating of the appliance.

WHAT TO DO IF YOU SMELL GAS

- Do not try to light any appliance.
- Do not touch any electrical switch.
- Do not use any phone in your building.
- Immediately call your gas supplier from a neighbor's phone. Follow the gas supplier's instructions.
- If you cannot reach your gas supplier, call the fire department.

Installation and service must be performed by a qualified installer, service agency or the gas supplier.

Safety and warnings	2
Introduction	5
Using your cooktop	6
Cooking guidelines and cookware	9
Care and cleaning	10
Troubleshooting	14
Warranty and service	17

IMpORTANT!

SAVE THESE INSTRUCTIONS

The models shown in this user guide may not be available in all markets and are subject to change at any time. For current details about model and specification availability in your country, please go to our website www.fisherpaykel.com or contact your local Fisher & Paykel dealer.

SAFETY AND WARNINGS

⚠ WARNING!



Poisoning Hazard

Never use this appliance as a space heater to heat or warm the room. Doing so may result in carbon monoxide poisoning and overheating of the appliance.

Failure to follow this advice may result in poisoning or death.

⚠ WARNING!



Hot Surface Hazard

This appliance becomes hot during use.

Do not touch the cooktop components, burners, pan supports or the stainless steel surfaces when hot.

Before cleaning, turn the burners off and make sure the whole cooktop is cool.

Failure to follow this advice may result in serious injury.

⚠ WARNING!



Fire Hazard

Never leave the appliance unattended when in use.

Boilover causes smoking and greasy spillovers that may ignite.

Failure to follow this advice may result in serious injury.

⚠ WARNING!



Explosion Hazard

Do not use or store flammable materials such as gasoline near the appliance.

Do not spray aerosols in the vicinity of this appliance while it is in operation.

Failure to follow this advice may result in injury or death.

⚠ WARNING!



Electrical Shock Hazard

Switch the power to the cooktop off at the wall before cleaning or maintenance.

Failure to follow this advice may result in electrical shock.

IMPORTANT SAFETY INSTRUCTIONS!

Operational

- **Keep children away from the cooktop when it is in use.**
- **Household appliances are not intended to be played with by children.**
- **Children of less than 8 years old must be kept away from the appliance unless continuously supervised. This appliance can be used by children aged from 8 years and above, and persons with reduced physical, sensory or mental capabilities or lack of experience and knowledge, if they have been given supervision or instruction concerning the use of the appliance in a safe way and they understand the hazards involved. Cleaning and user maintenance shall not be done by children without supervision.**
- **If the electrical supply cord is damaged, it must only be replaced by an authorized person.**
- **If the appliance is connected to the gas supply with a flexible hose, make sure that the hose cannot come in contact with the bottom of the appliance or any sharp edges.**
- **Ensure that the electrical connection plug is accessible after installation.**
- **This appliance should be connected to a circuit that incorporates an isolating switch providing full disconnection from the electricity supply.**
- **Do not use an asbestos mat or decorative covers between the flame and the saucepan as this may cause serious damage to your cooktop.**
- **Do not place aluminium foil or plastic dishes on the cooktop burners.**
- **Do not let large saucepans, frying pans or woks push any other pans aside. This could make them unstable or deflect heat onto your countertop and damage the surface.**
- **Do not use a steam cleaner for cleaning this cooktop.**
- **Saucepan handles may be hot to touch. Ensure saucepan handles do not overhang other gas burners that are on. Keep handles out of reach of children.**
- **Do not stand or place heavy objects on this appliance.**
- **After use, ensure that the control dials are in the OFF position.**
- **Where this appliance is installed in marine craft or in caravans, it shall not be used as a space heater.**
- **The use of a gas cooking appliance results in the production of heat and moisture in the room in which it is installed. Ensure the kitchen is well ventilated. Keep natural ventilation holes open or install a mechanical ventilation device (mechanical extractor hood). Prolonged intensive use of the appliance may call for additional ventilation, for example opening of a window, or more effective ventilation, for example increasing the level of mechanical ventilation where present.**
- **After having unpacked the appliance, check to ensure that it is not damaged.**
- **In case of doubt, do not use it and consult your supplier or a professionally qualified technician.**
- **Packing elements (eg plastic bags, polystyrene foam, nails, packing straps, etc.) should not be left around within easy reach of children, as these may cause serious injuries.**
- **Do not modify this appliance.**
- **This appliance is to be serviced only by an authorized person.**
- **Some products are supplied with protective film on steel and aluminium parts. This film must be removed before using the appliance.**

IMPORTANT SAFETY INSTRUCTIONS!

Operational

- Ensure the area around the gas cooktop is always clear of combustible materials, gasoline and other flammable vapors and liquids.
- Do not stand on this gas appliance.
- For safety reasons, do not store items of interest to children above or at the back of the appliance - children climbing on the appliance to reach items could be seriously injured.
- When deep-frying in fat, be sure the pan is large enough to avoid boiling over from bubbling of the fat. Do not deep-fry foods with a high moisture content or food covered with frost.
- Do not let cooking grease or other flammable materials accumulate near the appliance.
- Do not repair or replace any part of the appliance unless specifically recommended in this user guide.
- This appliance is to be serviced only by an authorized person.
- The Governor of California is required to publish a list of substances known to the state of California to cause cancer or reproductive harm and requires businesses to warn customers of potential exposures to such substances.

WARNING! Gas appliances contain or produce substances which can cause death or serious illness and which are known to the State of California to cause cancer, birth defects or other reproductive harm. To reduce the risk from substances in fuel or from fuel combustion, make sure this appliance is installed, operated, and maintained according to the manufacturer's instructions.

About your new cooktop

Thank you for buying a Fisher & Paykel gas cooktop. We recommend you read the whole guide before using your new cooktop, for both safety and cooking success. For more information, visit our local website listed on the back cover.

Safety feature: Auto-reignition

Auto-reignition is for your convenience and safety. The auto-reignition feature causes the igniters to spark automatically and the burner to relight if a flame blows out or if the flame is severely distorted by a draft or a cooktop ventilation system.

Before using the cooktop for the first time

- Read this user guide, taking special notice of the 'Safety and Warnings' section.
- Check that the pan supports are all in place and stable, and the flame spreaders, burner caps and rings are all seated correctly.
- Check that the installer has completed the 'Final checklist' in the Installation instructions.
- Ensure the power supply to the cooktop is turned on.

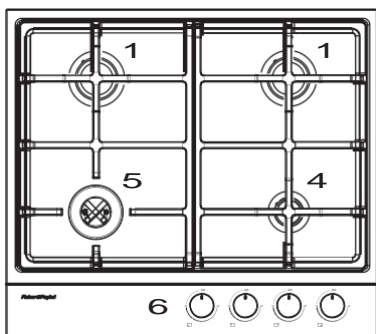

Cooktop layout - CG244D

- 1 Semi-rapid burner
- 2 Rapid burner
- 3 Dual wok burner
- 4 Auxiliary burner
- 5 Mini wok burner
- 6 Control dials

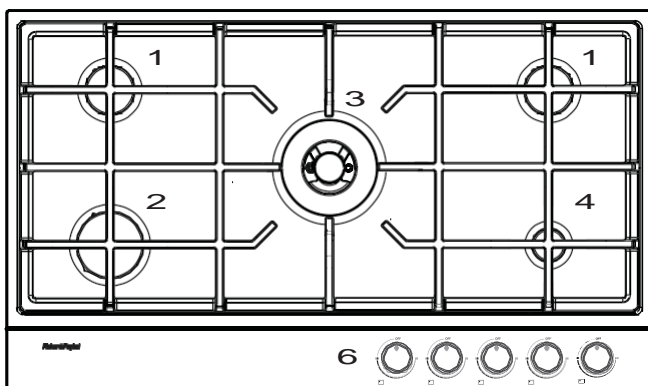

Cooktop layout - CG305D & CG365D

USING yOUR COOKTOP

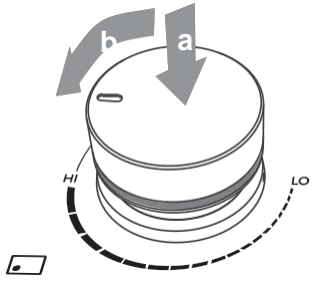
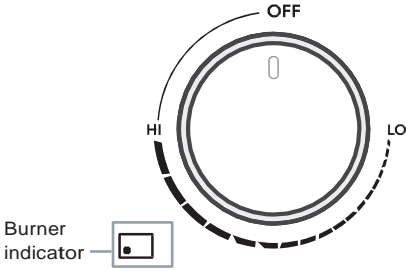

1 Identify the dial of the burner you want to use.

- 2 Press down (a) then turn counter-clockwise to HI (b).
- The igniters will start clicking as they spark.
 - If there is no clicking, there is no spark to light the burner. If the burner fails to light turn the dial back to OFF and see 'Troubleshooting'.

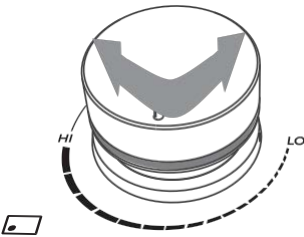

3 After the burner has lit, adjust the flame anywhere between HI and LO.

- Do not adjust or leave the dial between HI and OFF.

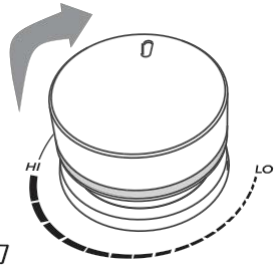

- 4 When you have finished cooking, turn the dial clockwise back to OFF.
- Check that the burner has gone out.
 - Before leaving the kitchen, check that all burners have been turned off.

Adjusting the flame on the Dual wok burner

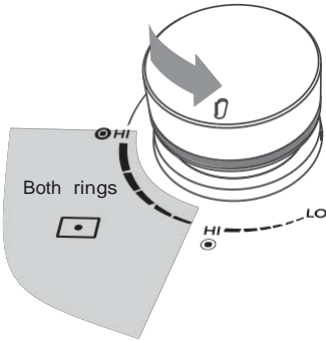

- 1 Always start out on HI. Both rings of flame will be on in the shaded setting range.

Note: when turned all the way down, the flame on the outer ring may appear to come and go. If this occurs, adjust the dial slightly back towards HI for a stable outer ring.

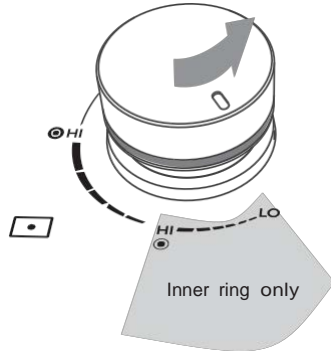

- 2 To use the inner ring of flames only, continue turning the dial towards LO. Only the inner ring will be on in the shaded setting range.

IMpORTANT!

Turn the burner **OFF** and see 'Troubleshooting' for what to do next if you experience any of the following:

- There's a strong gas smell.
- The flame has been blown out by a draft or extinguished by a spill and does not re-ignite.
- There is no clicking/sparking or there is clicking/sparking, but a burner or burners won't light.
- The flames don't burn all the way around a burner, or some flames flicker.
- The flame is yellow or yellow-tipped rather than blue.
- The flames are too large, small, irregular, noisy or lift away from the burner.

USING yOUR COOKTOP

Wok cooking

Use your wok only on the dual wok or mini-wok burner and with the supplied wok stand in place, as shown.

IMpORTANT!

- **Make sure that the wok stand is stable: its notches need to fit tightly over the pan supports, as shown.**
- **Make sure the wok does not push any other pans aside. This could make them unstable, or deflect heat onto nearby walls or the countertop.**

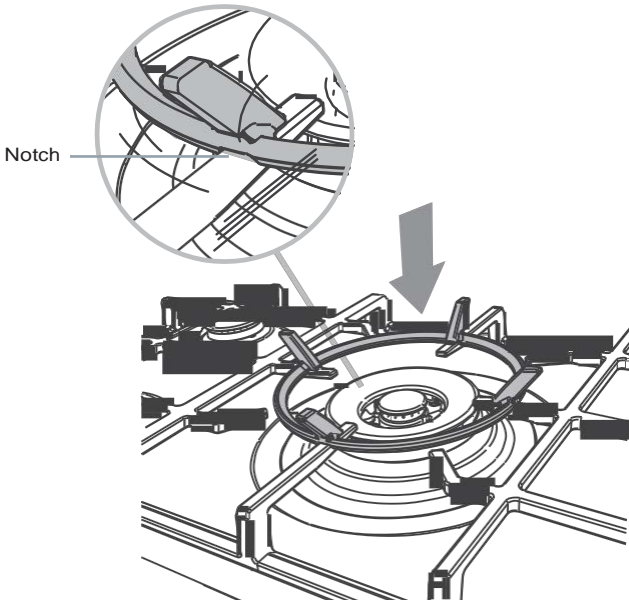

CG365D Dual Wok burner illustrated

Small pan support

Use the supplied small pan support to keep small diameter pans stable.

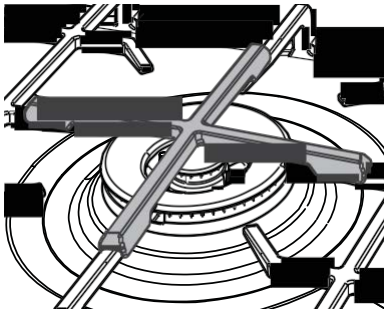

Cooking guidelines

IMpORTANT!

- **Never leave the cooktop unattended when in use. Boilover causes smoking and greasy spills that may ignite.**
- **Take care when deep-frying: oil or fat can overheat very quickly, particularly on a high setting.**
- Using a lid will reduce cooking times through retaining the heat.
- Minimise the amount of liquid to reduce cooking times.

Cookware

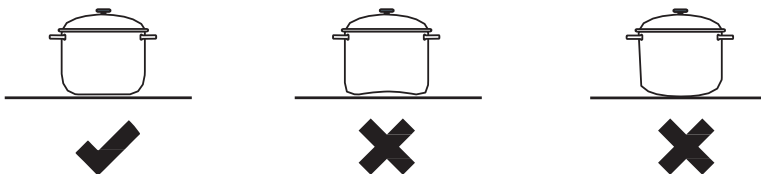

- Use saucepans with thick flat bases.
- Do not let large saucepans or frying pans overlap the bench, as this can deflect heat onto your countertop and damage its surface.
- Always make sure saucepans are stable by centring them over the burner.
- Make sure the size of the pan matches the size of the burner. A small pot on a large burner is not efficient. The following table shows the minimum and maximum saucepan base diameters that may be used on each burner:

BURNER		MINIMUM DIAMETER	MAXIMUM DIAMETER
Auxiliary		n/a	8 1/2" (22 cm)
Semi-rapid		n/a	8 1/2" (22 cm)
Rapid		n/a	8 1/2" (22 cm)
Mini Wok	regular pans (without small pan support)	5 7/8" (15 cm)	8 1/2" (22 cm)
	woks (with wok stand)	n/a	14 3/16" (36 cm)
Dual Wok	regular pans (without small pan support)	7 7/8" (20 cm)	15 1/2" (40 cm)
	woks (with wok stand)	n/a	17 1/2" (45 cm)

CARE AND CLEANING

IMPORANT!

Before any cleaning or maintenance, always:

- turn all burners off.
- switch the power to the cooktop off at the wall.
- make sure that the cooktop and its parts are a safe temperature to touch.

General advice

- Clean the cooktop regularly—do not let stains become burnt on, as they may become very difficult to remove.
- Do not use abrasive cleaners, cloths or pads to clean any part of your cooktop. Some nylon scourers may also scratch. Check the label.
- Clean up spillages as soon as possible. If left to dry on, food residue may clog the flame ports, causing an uneven flame pattern.
- Make sure that no cleaner residue is left on any cooktop part; when heated, these could stain the cooktop.
- See the following pages for instructions on replacing the pan supports and reassembling the burners correctly after cleaning.
- Do not clean cooktop parts in a self-cleaning oven.
- Do not use a steam cleaner.

WHAT? HOW OFTEN?	HOW?	IMPORTANT!
Stainless steel base After every use	<ol style="list-style-type: none">1 Soak any stubborn stains under a hot soapy cloth.2 Wipe the soiling off with a cloth using a mild household detergent or stainless steel cleaner.3 Wipe with a clean damp cloth.4 Wipe the surface dry with a microfiber cloth.5 For extra shine, use a suitable stainless steel polish. <ul style="list-style-type: none">• Hard water spots can be removed with household white vinegar.	<ul style="list-style-type: none">• Do not use abrasive cleaners, steel soap pads or sharp objects on stainless steel.• Always read the label to make sure that your stainless steel cleaner does not contain chlorine compounds as these are corrosive and may damage the appearance of your cooktop.• Always rub the stainless steel in the direction of the grain.• The graphics are etched onto the steel by laser and will not rub off.
Control dials As needed	<ol style="list-style-type: none">1 Wipe with a damp cloth and mild detergent. Stainless steel cleaner can be used on the top surface of the dials only.2 Dry thoroughly with a soft cloth.	<ul style="list-style-type: none">• Do not use oven cleaner on the dials, as doing so may damage their coating.

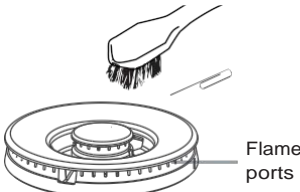
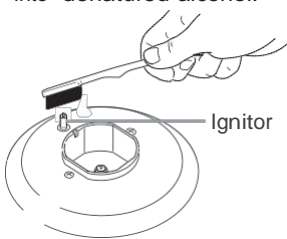
WHAT? HOW OFTEN?	HOW?	IMPORTANT!
<p>Burner caps and rings, flame spreaders, pan supports, wok stand</p> <p>As needed, but at least once a month</p>	<ol style="list-style-type: none"> 1 Remove the parts that you wish to clean. See the the illustrations following this chart. 2 Soak stubborn stains in a solution of biological clothes washing detergent or powdered dishwasher detergent. 3 Clean the parts in hot soapy water. Use a stiff nylon brush or straight-ended paper clip to clear the flame ports. <div style="text-align: center; margin: 10px 0;">  <p style="margin-left: 100px;">Flame ports</p> </div> <ol style="list-style-type: none"> 4 Rinse in warm water. 5 Dry thoroughly. 6 Replace the parts correctly, as shown in the drawings following this chart. 	<ul style="list-style-type: none"> • Make sure you keep the flame ports clear. Soiling from food spillage may clog these and cause ignition problems or uneven flame patterns. • Remove stains left by food or spillovers as soon as possible. If left to burn on, they may be difficult to remove or even permanently discolor these parts. • Before replacing the burner parts, make sure that they are completely dry. Wet burner parts may result in an irregular flame. • Before lighting a burner you have reassembled, check that all of its parts have been positioned correctly. Incorrect assembly can cause dangerous irregular flames and ignition problems.
<p>Ignitor</p> <p>At least once a month</p>	<p>Clean these very carefully using a toothbrush dipped into denatured alcohol.</p> <div style="text-align: center; margin: 10px 0;">  <p style="margin-left: 100px;">Ignitor</p> </div>	<p>A clean ignitor ensures trouble-free sparking. Check the ignitor regularly to make sure it is clean.</p>
<p>All gas components of the cooktop</p> <p>Once every 3-4 years</p>	<ul style="list-style-type: none"> • Contact your local Authorized Repairer to perform a thorough check on all gas components of the cooktop. • For Authorized Repairer details, see your Service & warranty book or contact Customer Care. 	<ul style="list-style-type: none"> • All checking and maintenance must be performed by a suitably qualified person. • If the gas is connected with a flexible hose, checking should include inspecting the entire length of the flexible hose assembly for any sign of wear or damage.

CARE AND CLEANING

Replacing the pan supports correctly

CG365D & CG305D models

The two pan supports are interchangeable. Fit them as shown and so that the rounded corners are to the outside, matching the cooktop base.

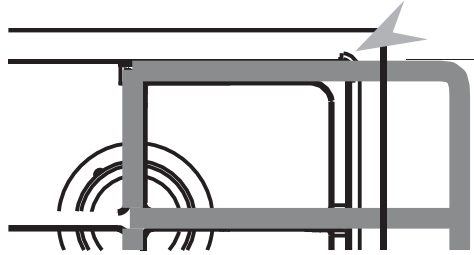
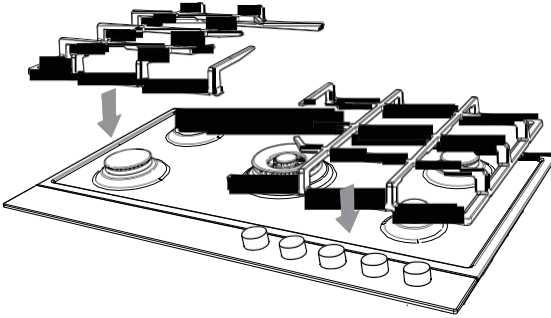

Correct positioning of pan supports

CG244D models

The pan supports can only be placed as shown and need to be rotated to match the rounded corners of the cooktop base and the opening fits over the mini-wok burner.

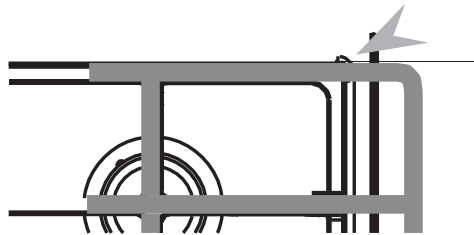
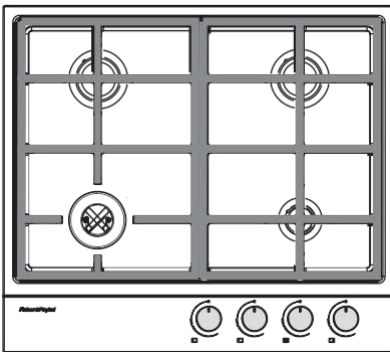

Correct positioning of pan supports (CG244D models)

Replacing the burner parts correctly

Semi-rapid, rapid, and auxiliary burners

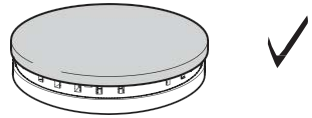
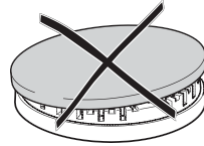
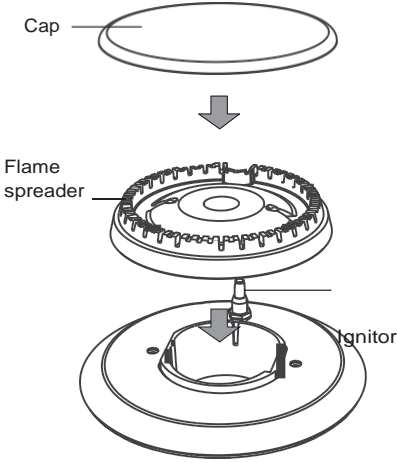

Dual Wok and Mini wok burners

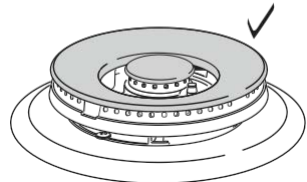
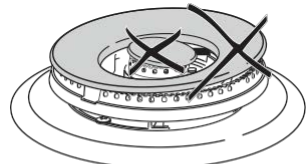
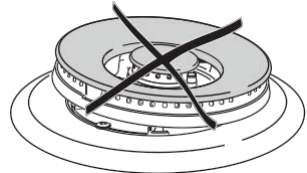
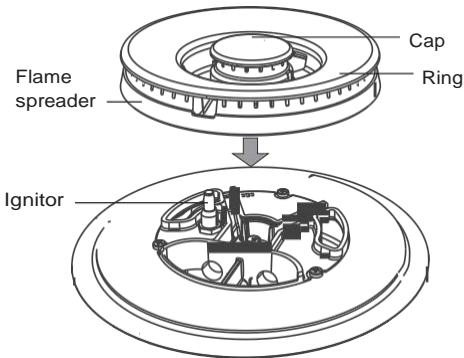

TROUBLESHOOTING

PROBLEM	POSSIBLE CAUSES AND SOLUTIONS
There is a strong gas smell.	<p>The gas connection could be leaking because of incorrect installation or damaged piping</p> <p>IMpORTANT! Do not use any electrical equipment or operate any electrical switches.</p> <ol style="list-style-type: none">1 If any burners are on, turn all of them off immediately.2 If you know how to shut off the gas supply to your cooktop (either at the valve or the gas bottle), do so.3 Open a window to let the gas out.4 Contact your local Authorized Repairer as soon as possible. <p>IMpORTANT! Do not use the cooktop until it has been repaired.</p>
There is a slight rubbery or metallic smell when I use the cooktop for the first time.	<p>This is normal for first use and is caused by manufacturing residues burning off. The smell will disappear with use.</p>
There is a power failure.	<p>You can still use your cooktop, but will need to match-light the burner(s). To do so, press down and turn the dial counter-clockwise to High while holding a lighted match close to the side of the burner. Wait until the flame is burning evenly before adjusting it.</p>
There is no clicking/sparking.	<p>There is a power failure. See entry 'There is a power failure' above.</p>
There is clicking/sparking, but a burner or burners won't light easily or at all.	<p>The ignitor(s) may be dirty or wet. Clean them following the instructions in 'Care and cleaning'.</p> <p>Wait 1 minute, then try to relighting the burner again, holding the dial for a few more seconds this time around. If this doesn't work and the burner still won't light, see the other possible causes and solutions below.</p> <p>The gas supply may not be turned on at the valve or gas bottle. Turn all the burners off, and check whether the gas supply to the cooktop is turned on.</p> <p>The gas supply to the house may not be working. You should hear the gas when you turn a burner on.</p> <p>If you use bottled gas, this may indicate you are getting near the end of the bottle and need to replace it.</p> <p>Burner parts may be clogged or wet. Make sure that they are clean and dry. See 'Care and cleaning' for instructions.</p> <p>Burner parts may not have been replaced correctly. Check the assembly and make sure the burner cap is sitting flat. See 'Care and cleaning' for illustrations.</p>

PROBLEM	POSSIBLE CAUSES AND SOLUTIONS
The flame has been blown out by a draft or extinguished by a spill.	The auto-reignition feature will recognise this. The ignitors will spark and attempt to relight the burner. If the burner fails to relight, turn the burner off, then wait for at least 1 minute before attempting to relight. This is to allow for any small amount of gas that may have escaped to disperse.
The flame goes out at low settings.	The gas supply pressure may be low. Check this with your service person or installer. If you use bottled gas, this may indicate you are getting near the end of the bottle
The flames are yellow or yellow-tipped rather than blue.	Burner parts (especially the flame ports) may be clogged or wet. Check that they are clean and dry. The cooktop may have been connected to the wrong type of gas or the gas pressure is not correct. Contact Customer Care and do not use your cooktop until it has been checked by a qualified technician.
The flame pattern is uneven around the burner.	Burner parts (especially the flame ports) may be clogged or wet. Check that they are clean and dry. See 'Care and cleaning' for instructions and illustrations on clearing clogged flame ports. After cleaning, check that there is flame coming out of each port.

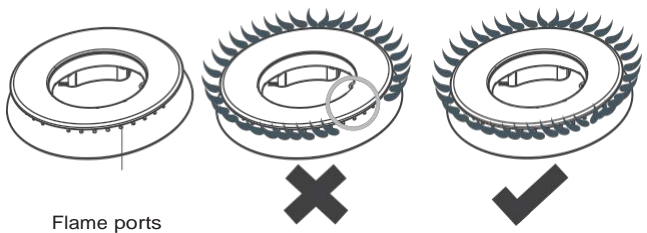

Burner parts may not have been replaced correctly. Check the assembly and make sure the burner cap and/ or ring is sitting flat on the flame spreader. See 'Care and cleaning' for illustrations.

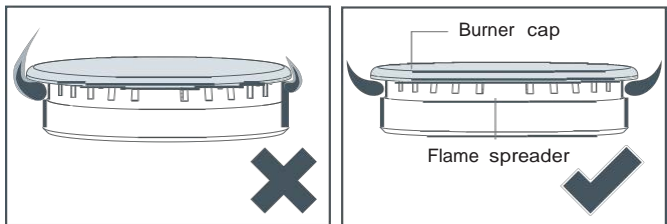

TROUBLESHOOTING

PROBLEM

The flames are too large, or too small.

The flames are noisy.

The flames lift away from the burner.

POSSIBLE CAUSES AND SOLUTIONS

The cooktop may have been connected to the wrong type of gas. Contact Customer Care and do not use your cooktop until it has been checked by a qualified technician.

Before you call for service or assistance ...

Check the things you can do yourself. Refer to the installation instructions and your user guide and check that:

- 1 Your product is correctly installed.
- 2 You are familiar with its normal operation.

If after checking these points you still need assistance or parts, please refer to the Service & Warranty book for warranty details and your nearest Authorized Service Centre, Customer Care, or contact us through our website www.fisherpaykel.com.

Contact details

A Service Summary is attached to the underside of the product.
For replacement parts or if further help is needed concerning this appliance call:

Toll Free 1 888 9 FNP USA (1 888 936 7872)

or write to:

Fisher & Paykel Appliances Inc.
5900 Skylab Road
Huntington Beach, CA 92647
USA

or contact us through our web site www.fisherpaykel.com

Complete and keep for safe reference:

Model _____
Serial _____ No.
Purchase Date _____
Purchaser _____
Dealer _____
Suburb _____
Town _____
Country _____

www.fisherpaykel.com

Copyright © Fisher & Paykel 2014. All rights reserved.

The product specifications in this booklet apply to the specific products and models described at the date of issue. Under our policy of continuous product improvement, these specifications may change at any time. You should therefore check with your Dealer to ensure this booklet correctly describes the product currently available.

Droits réservés © Fisher & Paykel 2014.

Les spécifications du produit contenues dans ce manuel s'appliquent aux modèles et produits spécifiques comme décrits à la date de publication.

Dans le cadre de notre politique d'améliorations en permanence de nos produits, ces spécifications pourront être modifiées à tout moment. Nous vous recommandons de vérifier auprès de votre revendeur que ce manuel décrit le produit actuellement disponible.

US CA