



*Thinking of you*  
**Electrolux**



---

**EN** REFRIGERATOR/FREEZER  
**FR** RÉFRIGÉRATEUR/CONGÉLATEUR

---

**USE AND CARE GUIDE**  
**GUIDE D'UTILISATION ET D'ENTRETIEN**



## Please read and save this guide

Thank you for choosing Electrolux, our new premium brand in home appliances. This Use & Care Guide is part of our commitment to customer satisfaction and product quality throughout the service life of your new appliance.

## Keep a record for quick reference

Purchase date

Electrolux model number

Electrolux serial number



### NOTE

Registering your product with Electrolux enhances our ability to serve you. You can register online at [www.electroluxappliances.com](http://www.electroluxappliances.com) or by sending your Product Registration Card in the mail.

## Questions?

For toll-free telephone support in the U.S. and Canada: 1-877-4ELECTROLUX (1-877-435-3287)

For online support and product information visit <http://www.electroluxappliances.com>

## Table of contents

|                                     |    |
|-------------------------------------|----|
| Finding Information .....           | 2  |
| Safety .....                        | 3  |
| Feature Overview.....               | 5  |
| Installation .....                  | 6  |
| Reversing the Door.....             | 7  |
| Controls .....                      | 11 |
| Storage Features .....              | 12 |
| Storing Food and Saving Energy..... | 13 |
| Normal Operating Sounds .....       | 14 |
| Care and Cleaning .....             | 15 |
| Common Solutions for Concerns ..... | 17 |
| Warranty.....                       | 19 |

## Installation Checklist

### Doors

- Handles are secure and tight
- Door seals completely to cabinet on all sides
- Freezer door is level across the top

### Leveling

- Refrigerator is level, side-to-side and tilted  $\frac{1}{4}$  inch (6 mm) front-to-back
- Toe grille is properly attached to refrigerator

- Cabinet is sitting solid on all corners

### Electrical Power

- House power turned on
- Refrigerator plugged in

### Final Checks

- Shipping material removed
- Fresh food and freezer temperatures set

## Important safety instructions

### Safety Precautions

Do not attempt to install or operate your unit until you have read the safety precautions in this manual. Safety items throughout this manual are labeled with a Danger, Warning, or Caution based on the risk type.

### Definitions

 This is the safety alert symbol. It is used to alert you to potential personal injury hazards. Obey all safety messages that follow this symbol to avoid possible injury or death.



### DANGER

DANGER indicates an imminently hazardous situation which, if not avoided, will result in death or serious injury.



### WARNING

WARNING indicates a potentially hazardous situation which, if not avoided, could result in death or serious injury.



### CAUTION

CAUTION indicates a potentially hazardous situation which, if not avoided, may result in minor or moderate injury.



### IMPORTANT

Indicates installation, operation, or maintenance information which is important but not hazard-related.

### General Safety



### WARNING

Please read all safety instructions before using your new refrigerator.

- Do not store or use gasoline or other flammable liquids near this or any other appliance. Read product labels for warnings regarding flammability and other hazards.
- Do not operate the refrigerator in the presence of explosive fumes.

- Avoid contact with any moving parts of the automatic ice maker.
- Remove all staples from the carton to avoid injury. Staples can also damage finishes if they come in contact with other appliances or furniture.

### Child Safety

#### Packing Materials:

- Packing cartons covered with rugs, bedspreads, plastic sheets, or stretch wrap may become airtight chambers and can quickly cause suffocation.
- Destroy or recycle the product's carton, plastic bags, and any other exterior wrapping material immediately after the refrigerator is unpacked. Children should never play with these items.

#### Child Entrapment and Suffocation:

- These problems are not limited to the past. Whether junked, abandoned, or temporarily stored (even for a few hours), unattended refrigerators and freezers are dangerous. Please take the precautions listed below.

#### Proper Disposal of Refrigerators/Freezers

We strongly encourage responsible appliance recycling/disposal methods. Check with your utility company or visit [www.energystar.gov/recycle](http://www.energystar.gov/recycle) for more information on recycling your old refrigerator.

Before you recycle or dispose of your old refrigerator/freezer:

- Remove the doors.
- Leave the shelves and baskets in place so children may not easily climb inside.
- Have refrigerant and compressor oil removed by a qualified service technician.

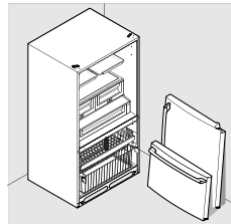

## Electrical information



### WARNING

**You must follow these guidelines to ensure that your refrigerator's safety mechanisms are operating correctly.**

- The refrigerator must be plugged into its own dedicated 115 Volt, 60 Hz, AC-only non-GFCI electric outlet. The power cord of the appliance is equipped with a three-prong grounding plug for protection against electrical shock hazards. It must be plugged directly into a properly grounded three-prong receptacle. The receptacle must be installed in accordance with local codes and ordinances. Consult a qualified electrician. Do not use an extension cord or adapter plug.
- If the power cord is damaged, it should be replaced by the manufacturer, service technician, or a qualified person.
- Never unplug the refrigerator by pulling on the power cord. Always grip the plug firmly and pull straight out from the receptacle to prevent damaging the power cord.
- To avoid electrical shock, unplug the refrigerator before cleaning and before replacing a light bulb or LED light.
- Performance may be affected if the voltage varies by 10% or more. Operating the refrigerator with insufficient power can damage the compressor. Such damage is not covered under your warranty.
- Do not plug the unit into an outlet controlled by a wall switch or pull cord to prevent the refrigerator from being turned off accidentally.

Grounding type wall receptacle

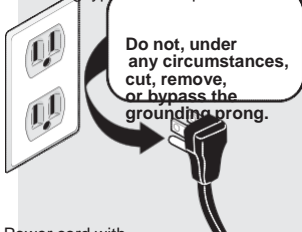

Power cord with  
3-prong grounded plug



### IMPORTANT

To turn off power to your refrigerator, unplug the power cord from the wall outlet.



### CAUTION

#### RISK OF FIRE OR ELECTRIC SHOCK!

During transportation and installation of the appliance, be certain that none of the components of the refrigerant circuit become damaged.

- Avoid open flames and sources of ignition.
- Thoroughly ventilate the room in which the appliance is situated.
- It is dangerous to alter the your specifications or modify this product in any way. Any damage to the cord may cause a short circuit, fire, and/or electric shock.
- The power cord must not be lengthened.
- Make sure that the power plug is not crushed or damaged. A crushed or damaged power plug may overheat and cause a fire.
- Make sure that you can access the main plug of the appliance.
- Do not pull the main cable.
- If the power plug socket is loose, do not insert the power plug. There is a risk of electric shock or fire.
- You must not operate the appliance without the interior lighting lamp cover.



### DANGER



DANGER Risk of fire or explosion. Flammable refrigerant used. Do not use mechanical devices to defrost refrigerator. Do not puncture refrigerant tubing.

DANGER Risk of fire or explosion. Flammable refrigerant used. To be repaired only by trained service personnel. Do not puncture refrigerant tubing.



### CAUTION



CAUTION Risk of fire or explosion. Flammable refrigerant used. Consult repair manual/owner's guide before attempting to service this product. All safety precautions must be followed.

CAUTION Risk of fire or explosion. Dispose of property in accordance with federal or local regulations. Flammable refrigerant used.

CAUTION- Risk of fire or explosion due to puncture of refrigerant tubing. Follow handling instructions carefully. Flammable refrigerant used.

## Understanding features and terms

Your Electrolux refrigerator is designed for optimal convenience and storage flexibility. The illustration below is provided to assist you with familiarizing yourself with product features and terminology.

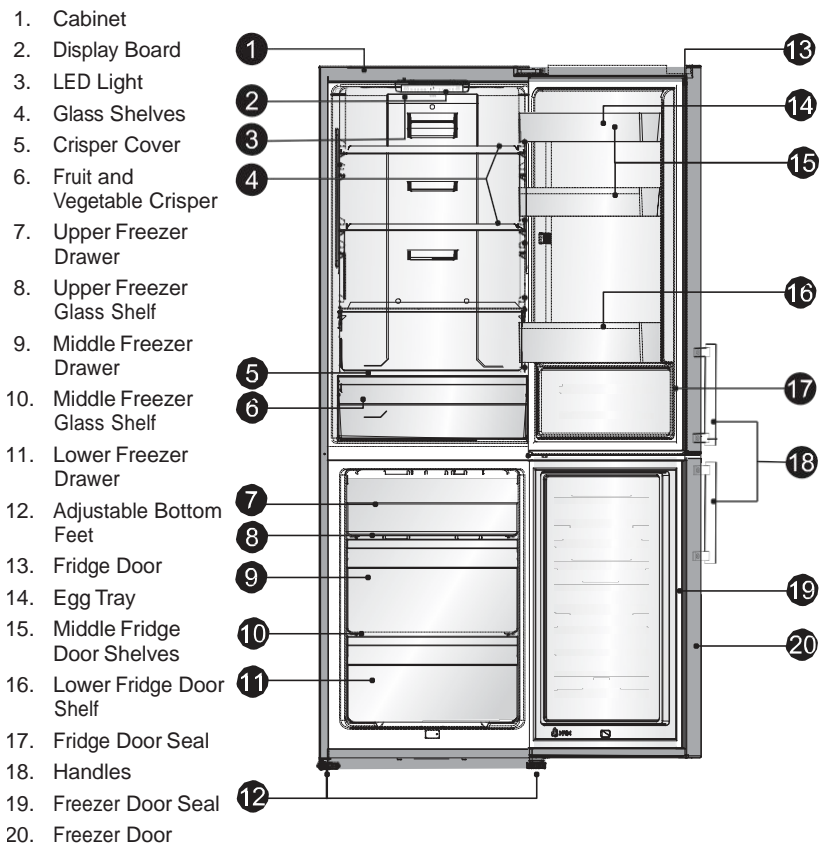

### IMPORTANT

If large quantities of food are to be stored in the freezer, all the freezer drawers (except the freezer lower drawer) can be taken out of the appliance and food stacked directly on the freezer shelves or in the freezer.



### NOTE

Features may vary according to model.

# 6 Installation

This Use & Care Guide provides general installation and operating instructions for your model. We recommend using a service or kitchen contracting professional to install your refrigerator. Use the refrigerator only as instructed in this Use & Care Guide. Before starting the refrigerator, follow these important first steps.

## Location

- Choose a place that is near a grounded, non-GFCI, electrical outlet. Do Not use an extension cord or an adapter plug.
- If possible, place the refrigerator out of direct sunlight and away from the range, dishwasher, or other heat sources.
- The refrigerator must be installed on a floor that is level and strong enough to support a fully loaded refrigerator.
- Consider water supply availability for models equipped with an automatic ice maker.



## CAUTION

DO NOT install the refrigerator where temperature will drop below 55°F (13°C) or rise above 110°F (43°C). The compressor will not be able to maintain proper temperatures inside the refrigerator.

DO NOT block the toe grille on the lower front of your refrigerator. Sufficient air circulation is essential for the proper operation of your refrigerator.

## Installation

Allow the following clearances for ease of installation, proper air circulation, and plumbing and electrical connections:

|             |                   |
|-------------|-------------------|
| Sides & Top | 4 inches (100 mm) |
| Back        | 3 inches (75 mm)  |



## IMPORTANT

It is necessary to have good ventilation around the refrigerator to allow for the dissipation of heat, high efficiency, and low power consumption. For this reason, sufficiently cleared space should be available around the refrigerator. It is advisable for there to be 3 inches (75 mm) separating the back of the refrigerator from the wall; at least 4 inches (100 mm) of space on its two sides; a height of over 4 inches (100 mm) from its top and a clear space in front to allow the doors to open 160°.

## Door opening

Your refrigerator should be positioned to allow easy access to a counter when removing food. For best use of refrigerator drawers and freezer baskets, the refrigerator should be in a position where both doors can be fully opened.

## Leveling

The appliance should be level in order to eliminate vibration. To make the appliance level, it should be upright and both the adjusters should be in stable contact with the floor. You can also adjust the level by unscrewing the appropriate level adjustment in the front (use your fingers or a suitable socket driver).

## Door Reversal

The side on which the door opens can be changed from the right side (as supplied) to the left side if the installation site allows.



### WARNING

When reversing the door, the appliance must not be connected to the power source. Ensure that the plug is removed from the power source.

Tools you will need:

|  |
|--|
|  |
|  |
|  |
|  |



### NOTE

Before you start, lay the refrigerator on its back in order to gain access to the base. You should rest it on soft foam packaging or similar material to avoid damaging the backboard of the refrigerator.

To reverse the door:

- 1 Stand the refrigerator upright. Open the upper door. Take out all door racks (to avoid damaging the racks) and then close the door.

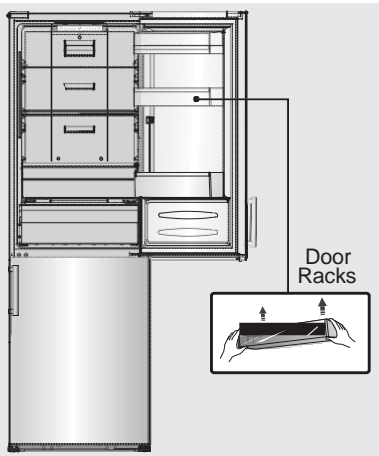

- 2 Open upper cover ① on top of the refrigerator body from right side and then remove the upper hinge cover ② and magnetic switch box ③.

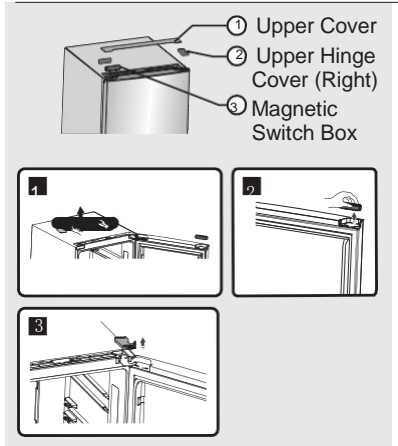

- 3 Remove the corner cover.

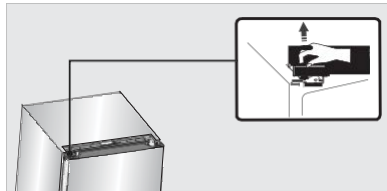

- 4 Remove the screws ①, and remove part ②.

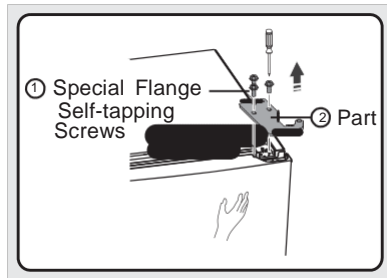

### CAUTION

Be sure doors are set aside in a secure position where they cannot fall and cause personal injury, or damage to the doors or handles.

# 8 Reversing the Door

5 Remove the upper door and place it on a smooth surface with its panel upwards. Lever part ① and part ④, then loose screws ②, as shown in the picture. Change handle ③ to the right side, then install screws ②, part ① and part ④ in turn. Loose screws ⑦, detach part ⑥ and part ⑤, then install part ⑤ and another part ⑥ (in the plastic bag) to the left side with screws ⑦. Put part ⑥, just detached, back into the plastic bag.

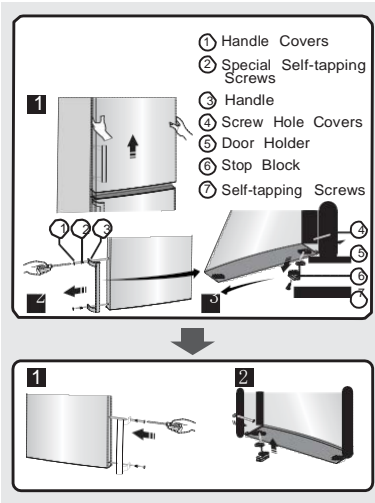

6 Loose screws used to fix the middle hinge and remove middle hinge. Then remove the lower door.

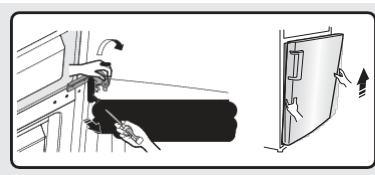

7 Place the lower door on a smooth surface with its panel upwards. Change the handle to the right side according to step 5. Loose screws ⑦. Detach part ⑥ and part ⑤. Turn part ⑤ by 180 degrees and then install part ⑤ and part ⑥ to the corresponding position on the left side together with the screws.

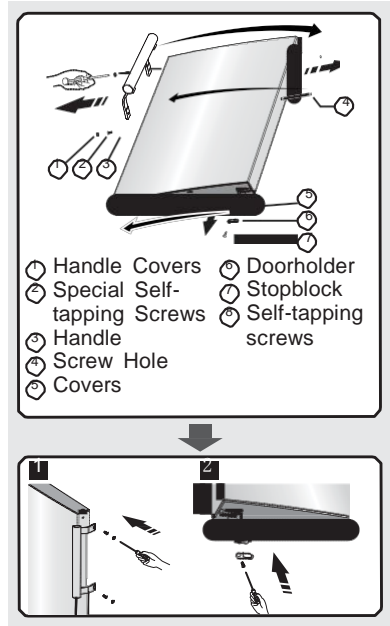

8 Change screw hole covers on middle cover plate from left to right (as shown in figure below).

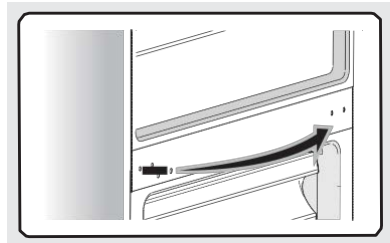



- 9 Place refrigerator flatwise, remove part ③ and then loose screws ④. Remove part ② and part ①.

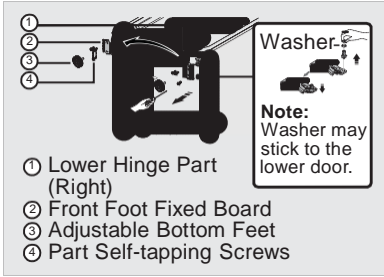

- 10 Screw out lower hinge, change it to the near hole site, and then screw up and mount washer.
- 11 Just remount to the step 9, change part ① to left and part ② to right and then fix them with screws ④. Finally install part ③.

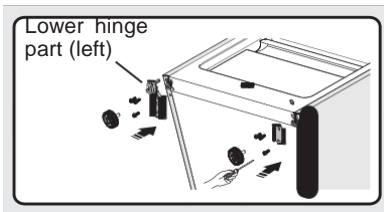

- 12 Move the lower door and adjust its position to align lower hole site and upper hinge axis. Turn the middle hinge by 180 degrees, change the washer on the axis to the upper side, adjust the middle hinge to the appropriate position and then install it.

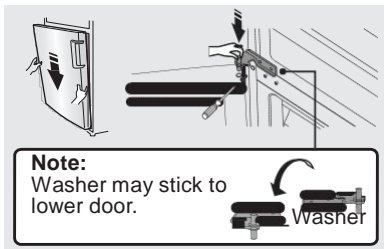

- 13 Screw out the upper hinge axis, turn the upper hinge over and fix axis on it. Then place it at side for use.

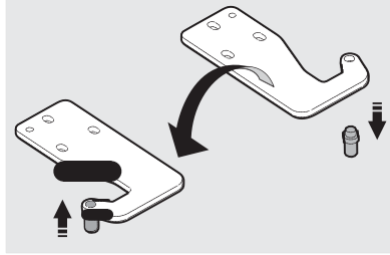

- 14 Exchange wires both in the left and right slots of refrigerator body.

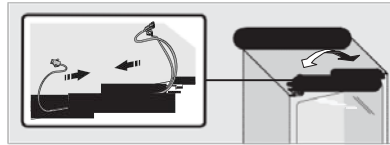

- 15 Move the upper door to appropriate position, adjust part ① and upper door, then fix part ① by screws ②. (Please hold upper door by hand when installing.)

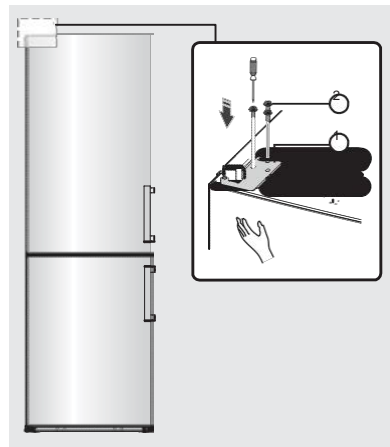

# 10 Reversing the Door

- 16 Install the upper hinge cover (which is in the plastic bag).

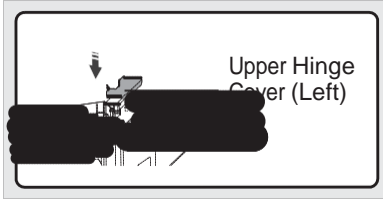

- 17 Reverse part ① and install it onto the right corner of upper door.

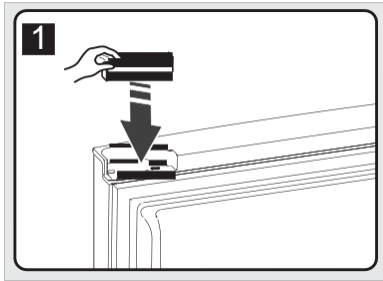

- 18 Take the reed switch out of the coping block (parts ③ and ④ in step 3) and mount it on another block for use (which is marked "R" in the plastic bag). Put the coping block just removed back into the plastic bag.

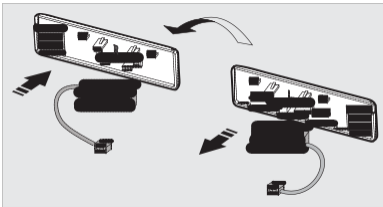

## NOTE

Be sure character side of reed switch fits well with coping block.

- 19 Install part ①, connect the wire connector ②, and then install part ③.

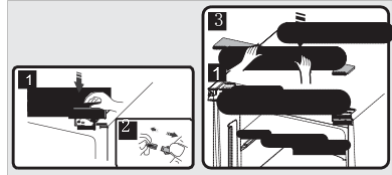

- 20 Open the upper door, mount door racks and then close the door.

Use your appliance according to the following control regulations. Your appliance has comparable functions and modes as the control panels shown in the pictures below. When the appliance is powered on for the first time, the backlighting of the icons on the display panel starts working. If no buttons have been pressed and the doors are closed, the backlighting will turn off.

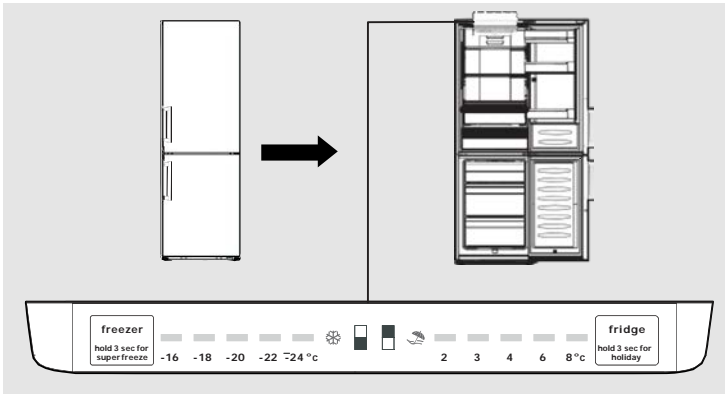

## Controlling the temperature

We recommend that when you start your refrigerator for the first time set the temperature for the refrigerator to 4°C and the freezer to -18°C. If you want to change the temperature, follow the instructions below.



### CAUTION

When you set a temperature, you set an average temperature for the whole refrigerator cabinet. Temperatures inside each compartment may vary from the temperature values displayed on the panel, depending on how much food you store and where you place the food. Ambient temperature may also affect the actual temperature inside the appliance.

## Fridge

Press the middle part of button  to set fridge temperature between 2°C and 8°C as needed, and control panel will display corresponding figures according to the following sequence. —

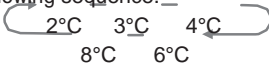

## Freezer

Press the middle part of button  to set fridge temperature between -16°C and -24°C as needed, and control panel will display corresponding figures according to the following sequence. — °C

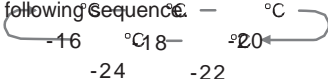

## Super Freeze

 Super Freeze will quickly lower the temperature within the freezer so food will freeze vitamins and nutrients of fresh food and keep food fresh longer.

- Press the middle part of button for 3 seconds to activate the super freeze function. The light will come on.
- In case of the maximum amount of food to be frozen, please wait about 24 hours.
- Super freeze automatically switches off after 26 hours.
- When super freeze function is on you can switch off super freeze function by pressing the middle part of button and the freezer temperature setting will revert back to the previous setting.

## Holiday

 If you are going to be away for a long period of time, you can activate this function by pressing the middle part of button for 3 seconds until the light comes on.

- When the holiday function is activated, the temperature of the refrigerator is automatically switched to 15°C to minimize the energy consumption.
- When the holiday function is on, you can switch it off by pressing the middle part of button. The fridge temperature setting will revert back to the previous setting.

# 12 Storage Features

## Accessories



### CAUTION

To avoid injury from breakage, handle tempered glass shelves carefully.



### NOTE

Features may vary according to model.

## Movable shelves/trays

- Various glass and plastic storage shelves or wire trays are included with your appliance.
- The walls of the refrigerator are equipped with a series of runners so that the shelves can be positioned as desired.
- To permit storage of food packages of various sizes, the door shelves can be placed at different heights.
- To adjust, gradually pull the shelf in the direction of the arrows until it comes free, then reposition as required.

## Vegetable drawer

For storing fruits and vegetables.

## Freezer drawer

For storing frozen foods.

## Ice cube tray

For making ice and storing ice cubes.



### CAUTION

Shelves must be removed prior to moving the refrigerator.

## Ideas for storing foods

### Fresh food storage

- Do not store warm foods or evaporating liquids in the appliance.
- Do cover or wrap the food, particularly if it has a strong flavor.
- Avoid overcrowding the refrigerator shelves, which reduces air circulation and causes uneven cooling.

### Fruits and vegetables

- Store fruits and vegetables in crisper drawers, where trapped moisture helps preserve food quality for longer time periods.
- Wash items and remove excess water.
- Wrap any items that have strong odors or high moisture content.

### Meat

- Wrap raw meat and poultry separately and securely to prevent leaks and contamination of other foods or surfaces.
- Any meat to be kept longer than two days should be frozen.

### Frozen food storage

- Make sure that the commercially frozen food was stored by the retailer.
- Once defrosted, foods deteriorate rapidly and can not be re-frozen.
- Do not exceed the storage period indicated by the food manufacturer.
- A freezer operates most efficiently when it is at least  $\frac{2}{3}$  full.

### Packaging foods for freezing

- To minimize food dehydration and quality deterioration, use aluminum foil, freezer wrap, freezer bags, or airtight containers. Force as much air out of the packages as possible and seal them tightly. Trapped air can cause food to dry out, change color, and develop an off-flavor (freezer burn).
- Wrap fresh meats and poultry with suitable freezer wrap prior to freezing.
- Do not refreeze meat that has completely thawed.

### Loading the freezer

- Prior to grocery shopping, activate Super freeze so that on your return

you can ensure your newly purchased food designated for the freezer will be preserved as quickly as possible.

- Activating Super freeze also will help your freezer more efficiently maintain the selected temperature after placing new purchases with pre-existing frozen foods.
- Avoid adding too much warm food to the freezer at one time. This overloads the freezer, slows the rate of freezing, and can raise the temperature of frozen foods.
- Leave a space between packages, so cold air can circulate freely, allowing food to freeze as quickly as possible.

## Ideas for saving energy

### Installation

- Locate the refrigerator in the coolest part of the room, out of direct sunlight, and away from heating ducts or registers.
- Do not place the refrigerator next to heat-producing appliances such as a range, oven, or dishwasher. If this is not possible, a section of cabinetry or an added layer of insulation between the two appliances will help the refrigerator operate more efficiently.
- Level the refrigerator so that the doors close tightly.

### Temperature settings

- Refer to the Controls section for procedures on temperature settings.

### Food storage

- Avoid overcrowding the refrigerator or blocking cold air vents. Doing so causes the refrigerator to run longer and use more energy.
- Cover foods and wipe containers dry before placing them in the refrigerator. This cuts down on moisture build-up inside the unit.
- Organize the refrigerator to reduce door openings. Remove as many items as needed at one time and close the door as soon as possible.
- Do not place a hot container directly on a cold shelf. Remember, such an extreme temperature change may damage the glass.

# 14 Normal Operating Sounds

---

## Understanding the sounds you may hear

Your new, high-efficiency refrigerator may introduce unfamiliar sounds. These sounds normally indicate your refrigerator is operating correctly. Some surfaces on floors, walls, and kitchen cabinets may make these sounds more noticeable.

- Clicks** Whenever the compressor switches on or off, a click can be heard.
- Humming** As soon as the compressor is in operation, you can hear it humming.
- Bubbling** When refrigerant flows into thin tubes, you can hear bubbling or splashing noises.
- Splashing** Even after the compressor has been switched off, this noise can be heard for a short time.



### NOTE

Energy efficient foam in your refrigerator is not a sound insulator.

---

## Protecting your investment

Keeping your refrigerator clean maintains its appearance and prevents odor build-up. Wipe up any spills immediately and clean the freezer and fresh food compartments at least twice a year.



### NOTE

Do not use abrasive cleaners such as window sprays, scouring cleansers, flammable fluids, cleaning waxes, concentrated detergents, bleaches, or cleansers containing petroleum products on plastic parts, interior doors, gaskets, or cabinet liners. Do not use paper towels, scouring pads, or other abrasive cleaning materials.

- Never use metallic scouring pads, brushes, abrasive cleaners, or strong alkaline solutions on any surface.
- Never use CHLORIDE or cleaners with bleach to clean stainless steel.
- Do not wash any removable parts in a dishwasher.



### NOTE

If you set your temperature controls to turn off cooling, power to lights and other electrical components will continue until you unplug the power cord from the wall outlet.

- Always unplug the electrical power cord from the wall outlet before cleaning.
- Remove adhesive labels by hand. Do not use razor blades or other sharp instruments which can scratch the appliance surface.
- Do not remove the serial plate. Removal of your serial plate voids your warranty.
- Before moving your refrigerator, raise the anti-tip brackets so the rollers will work correctly. This will prevent the floor from being damaged.



### CAUTION

- Pull the refrigerator straight out to move it. Shifting it from side to side may damage flooring. Be careful not to move the refrigerator beyond the plumbing connections.
- Damp objects stick to cold metal surfaces. Do not touch refrigerated surfaces with wet or damp hands.



### IMPORTANT

If you store or move your refrigerator in freezing temperatures, be sure to completely drain the water supply system. Failure to do so could result in water leaks when the refrigerator is put back into service. Contact a service representative to perform this operation.

Refer to the guide on the next page for details on caring and cleaning specific areas of your refrigerator.

# 16 Care and Cleaning

## Care and cleaning tips

| Part   | Cleaning Agents   | Tips and Precautions  |
|--|---|---|
| Interior & Door Liners                           | <ul style="list-style-type: none"><li>• Soap and water</li><li>• Baking soda and water</li></ul>                      | <ul style="list-style-type: none"><li>• Use two tablespoons of baking soda in one quart of warm water.</li><li>• Be sure to wring excess water out of sponge or cloth before cleaning around controls, light bulb or any electrical part.</li></ul>   |
| Door Gaskets                                     | <ul style="list-style-type: none"><li>• Soap and water</li></ul>  | <ul style="list-style-type: none"><li>• Wipe gaskets with a clean soft cloth.</li></ul>   |
| Drawers & Bins                                   | <ul style="list-style-type: none"><li>• Soap and water</li></ul>  | <ul style="list-style-type: none"><li>• Use a soft cloth to clean drawer runners and tracks.</li><li>• Do not wash any removable items (bins, drawers, etc.) in dishwasher.</li></ul>   |
| Glass Shelves                                    | <ul style="list-style-type: none"><li>• Soap and water</li><li>• Glass cleaner</li><li>• Mild liquid sprays</li></ul> | <ul style="list-style-type: none"><li>• Allow glass to warm to room temperature before immersing in warm water.</li></ul>   |
| Exterior & Handles                               | <ul style="list-style-type: none"><li>• Soap and water</li><li>• Non abrasive glass cleaner</li></ul>                 | <ul style="list-style-type: none"><li>• Do not use commercial household cleaners containing ammonia, bleach or alcohol to clean handles.</li><li>• Use a soft cloth to clean smooth handles.</li><li>• Do not use a dry cloth to clean smooth doors.</li></ul>  |
| Exterior & Handles (Stainless Steel Models Only) | <ul style="list-style-type: none"><li>• Soap and water</li><li>• Stainless steel cleaners</li></ul>                   | <ul style="list-style-type: none"><li>• Never use CHLORIDE or cleaners with bleach to clean stainless steel.</li><li>• Clean stainless steel front and handles with non-abrasive soapy water and a dishcloth. Rinse with clean water and a soft cloth.</li><li>• Use a non-abrasive stainless steel cleaner. These cleaners can be purchased at most home improvement or major department stores. Always follow manufacturer's instruction. Do not use household cleaners containing ammonia or bleach.</li><li>• NOTE: Always clean, wipe and dry with grain to prevent scratching.</li><li>• Wash the rest of the cabinet with warm water and mild liquid detergent. Rinse well and wipe dry with a clean soft cloth.</li></ul> |

## Vacation and moving tips

| Occasion        | Tips   |
|-----------------|--|
| Short Vacations | <ul style="list-style-type: none"><li>• Leave refrigerator operating during vacations of three weeks or less.</li><li>• Use all perishable items from refrigerator compartment.</li><li>• Turn automatic ice maker off and empty ice bucket, even if you will only be gone a few days.</li></ul>                                       |
| Long Vacations  | <ul style="list-style-type: none"><li>• Remove all food and ice if you will be gone one month or more.</li><li>• Turn the cooling system to Vacation/Holiday mode (see Controls section).</li><li>• Clean interior thoroughly.</li><li>• Leave doors open to prevent odors and mold build-up. Block doors open if necessary.</li></ul> |
| Moving          | <ul style="list-style-type: none"><li>• Remove all food and ice.</li><li>• If using a handcart, load from the side.</li><li>• Adjust rollers all the way up to protect them during sliding or moving.</li><li>• Pad cabinet to avoid scratching surface.</li></ul>   |



## Before you call...

If you experience a concern with your refrigerator or notice a product behavior or condition that you do not understand, you can usually avoid a call to your service representative by referring to this section for an answer. Beginning with the following table, this information includes concerns, potential causes, and common solutions.

| <b>Opening/Closing Of Doors/Drawers</b>    |  |   |
|--|--|---|
| Concern                                    | Potential Cause  | Common Solution   |
| Door(s) will not close.                    | <ul style="list-style-type: none"> <li>Refrigerator is not level. It rocks on the floor when moved slightly.</li> <li>An object has fallen from the baskets blocking the door from closing.</li> </ul>   | <ul style="list-style-type: none"> <li>Ensure floor is level and solid, and can adequately support the refrigerator. Contact a carpenter to correct a sagging or sloping floor.</li> <li>Check for ice or food items blocking drawer.</li> </ul>  |
| Drawers are difficult to move.             | <ul style="list-style-type: none"> <li>Food is touching shelf on top of drawer.</li> <li>Drawer is overloaded.</li> </ul>  | <ul style="list-style-type: none"> <li>Keep less food in drawer.</li> <li>Remove or redistribute food.</li> </ul>   |
| <b>Refrigerator Operations</b>             |  |   |
| Concern                                    | Potential Cause  | Common Solution   |
| Compressor does not run.                   | <ul style="list-style-type: none"> <li>Cooling system is turned Off.</li> <li>Refrigerator is in defrost cycle.</li> <li>Plug at wall outlet is disconnected.</li> <li>House fuse is blown or a tripped circuit breaker.</li> <li>Power outage.</li> <li>Electronic control system keeps the refrigerator at a constant temperature.</li> </ul>  | <ul style="list-style-type: none"> <li>Turn cooling system On. See Controls Section for location of cooling system On/Off button.</li> <li>This is normal for a fully automatic defrost refrigerator. The defrost cycle occurs periodically, lasting about 30 minutes.</li> <li>Ensure plug is tightly pushed into outlet.</li> <li>Check/replace fuse with a 15 amp time-delay fuse. Reset circuit breaker.</li> <li>Check house lights. Call local Electric Company.</li> <li>This is normal. Refrigerator goes on and off to keep temperature constant.</li> </ul>   |
| Refrigerator runs too much or too long.    | <ul style="list-style-type: none"> <li>Room or outside weather is hot.</li> <li>Refrigerator has recently been disconnected for a period of time.</li> <li>Doors are opened too frequently or too long.</li> <li>Refrigerator/freezer door may be slightly open.</li> <li>Freezer control is set too cold.</li> <li>Fresh food/freezer gasket is dirty, worn, cracked, or poorly fitted.</li> <li>This model is provided with a high-efficiency, variable-speed compressor.</li> </ul> | <ul style="list-style-type: none"> <li>It's normal for the refrigerator to work longer under these conditions.</li> <li>It takes 8-12 hours for the refrigerator to cool down completely.</li> <li>Warm air entering the refrigerator causes it to run more. Open doors less often.</li> <li>Ensure refrigerator is level. Keep food and containers from blocking door.</li> <li>Set freezer control to warmer setting until refrigerator temperature is satisfactory. Allow 24 hours for temperature to stabilize.</li> <li>Clean or change gasket. Leaks in door seal will cause refrigerator to run longer in order to maintain desired temperatures.</li> <li>It is normal for the compressor to run for long periods of time.</li> </ul> |
| Digital temperature displays are flashing. | <ul style="list-style-type: none"> <li>Electronic control system has detected a performance problem.</li> </ul>  | <ul style="list-style-type: none"> <li>Call your Electrolux service representative who can interpret any messages or number codes flashing on the digital displays.</li> </ul>  |

# 18 Common Solutions for Concerns

## Temperatures Are Too Cold

| Concern   | Potential Cause   | Common Solution  |
|---|---|--|
| Freezer temperature too cold. Refrigerator temperature is satisfactory. | <ul style="list-style-type: none"> <li>• Super freeze function is activated.</li> <li>• Freezer control is set too cold.</li> </ul> | <ul style="list-style-type: none"> <li>• Deactivate Super freeze function.</li> <li>• Set freezer control to a warmer setting. Allow 24 hours for temperature to stabilize.</li> </ul> |
| Refrigerator temperature too cold. Freezer temperature is satisfactory. | <ul style="list-style-type: none"> <li>• Refrigerator control is set too cold.</li> </ul>   | <ul style="list-style-type: none"> <li>• Set refrigerator control to a warmer setting. Allow 24 hours for temperature to stabilize.</li> </ul>   |
| Food stored in drawers freezes.   | <ul style="list-style-type: none"> <li>• Refrigerator control is set too cold.</li> </ul>   | <ul style="list-style-type: none"> <li>• Set refrigerator control to a warmer setting. Allow 24 hours for temperature to stabilize.</li> </ul>   |

## Temperatures Are Too Warm

| Concern  | Potential Cause  | Common Solution  |
|--|--|--|
| Freezer/ Refrigerator temperature is too warm.                             | <ul style="list-style-type: none"> <li>• Doors are opened too frequently or too long.</li> <li>• Door is slightly open.</li> </ul> | <ul style="list-style-type: none"> <li>• Warm air enters the refrigerator whenever the door is opened. Open the door less often.</li> <li>• Close door.</li> </ul> |
| Freezer temperature is too warm. Refrigerator temperature is satisfactory. | <ul style="list-style-type: none"> <li>• Freezer control is set too warm.</li> </ul>   | <ul style="list-style-type: none"> <li>• Set freezer control to a colder setting. Allow 24 hours for temperature to stabilize.</li> </ul>                          |
| Refrigerator temperature is too warm. Freezer temperature is satisfactory. | <ul style="list-style-type: none"> <li>• Refrigerator control is set too warm.</li> </ul>  | <ul style="list-style-type: none"> <li>• Set refrigerator control to a colder setting. Allow 24 hours for temperature to stabilize.</li> </ul>                     |

## Water/Moisture/Frost Inside Refrigerator

| Concern  | Potential Cause  | Common Solution   |
|--|--|---|
| Moisture collects on inside of refrigerator walls.             | <ul style="list-style-type: none"> <li>• Weather is hot and humid.</li> <li>• Door is slightly open.</li> <li>• Door is opened too often or too long.</li> <li>• Open containers.</li> </ul> | <ul style="list-style-type: none"> <li>• The rate of frost buildup and internal sweating increases.</li> <li>• Close door.</li> <li>• Open door less often to allow internal temperature to stabilize.</li> <li>• Keep containers covered.</li> </ul> |
| Water collects on bottom side of drawer cover.                 | <ul style="list-style-type: none"> <li>• Vegetables contain and give off moisture.</li> </ul>  | <ul style="list-style-type: none"> <li>• Moisture on the bottom side of the cover is not unusual.</li> <li>• Move humidity control (select models) to lower setting.</li> </ul>   |
| Moisture collects in bottom of drawer.                         | <ul style="list-style-type: none"> <li>• Washed vegetables and fruit drain while in the drawer.</li> <li>• Fruits and vegetables are kept past their prime</li> </ul>                        | <ul style="list-style-type: none"> <li>• Dry items before putting them in the drawer. Water collecting in bottom of drawer is normal.</li> <li>• Routinely clean out old fruits and vegetables especially if they begin to break down.</li> </ul>     |
| Moisture collects on outside of refrigerator or between doors. | <ul style="list-style-type: none"> <li>• Weather is humid.</li> <li>• Door is slightly open, causing cold air from inside refrigerator to meet warm air from outside.</li> </ul>             | <ul style="list-style-type: none"> <li>• This is normal in humid weather.</li> <li>• Close door.</li> </ul>   |

## Major Appliance Warranty Information

Your appliance is covered by a one year limited warranty. For one year from your original date of purchase, Electrolux will repair or replace any parts of this appliance that prove to be defective in materials or workmanship when such appliance is installed, used, and maintained in accordance with the provided instructions. In addition, the cabinet liner and sealed refrigeration system (compressor, condenser, evaporator, dryer or tubing) of your appliance is covered by a two through five year limited warranty. During the 2<sup>nd</sup> through 5<sup>th</sup> years from your original date of purchase, Electrolux will repair or replace any parts in the cabinet liner and sealed refrigeration system which prove to be defective in materials or workmanship when such appliance is installed, used, and maintained in accordance with the provided instructions.

### Exclusions

This warranty does not cover the following:

1. Products with original serial numbers that have been removed, altered or cannot be readily determined.
2. Product that has been transferred from its original owner to another party or removed outside the USA or Canada.
3. Rust on the interior or exterior of the unit.
4. Products purchased "as-is" are not covered by this warranty.
5. Food loss due to any refrigerator or freezer failures.
6. Products used in a commercial setting.
7. Service calls which do not involve malfunction or defects in materials or workmanship, or for appliances not in ordinary household use or used other than in accordance with the provided instructions.
8. Service calls to correct the installation of your appliance or to instruct you how to use your appliance.
9. Expenses for making the appliance accessible for servicing, such as removal of trim, cupboards, shelves, etc., which are not a part of the appliance when it is shipped from the factory.
10. Service calls to repair or replace appliance light bulbs, air filters, water filters, other consumables, or knobs, handles, or other cosmetic parts.
11. Pickup and delivery costs; your appliance is designed to be repaired in the home.
12. Surcharges including, but not limited to, any after hour, weekend, or holiday service calls, tolls, ferry trip charges, or mileage expense for service calls to remote areas, including the state of Alaska.
13. Damages to the finish of appliance or home incurred during transportation or installation, including but not limited to floors, cabinets, walls, etc.
14. Damages caused by: services performed by unauthorized service companies; use of parts other than genuine Electrolux parts or parts obtained from persons other than authorized service companies; or external causes such as abuse, misuse, inadequate power supply, accidents, fires, or acts of God.

### DISCLAIMER OF IMPLIED WARRANTIES; LIMITATION OF REMEDIES

CUSTOMER'S SOLE AND EXCLUSIVE REMEDY UNDER THIS LIMITED WARRANTY SHALL BE REPAIR OR REPLACEMENT AS PROVIDED HEREIN. CLAIMS BASED ON IMPLIED WARRANTIES, INCLUDING WARRANTIES OF MERCHANTABILITY OR FITNESS FOR A PARTICULAR PURPOSE, ARE LIMITED TO ONE YEAR OR THE SHORTEST PERIOD ALLOWED BY LAW, BUT NOT LESS THAN ONE YEAR. ELECTROLUX SHALL NOT BE LIABLE FOR CONSEQUENTIAL OR INCIDENTAL DAMAGES SUCH AS PROPERTY DAMAGE AND INCIDENTAL EXPENSES RESULTING FROM ANY BREACH OF THIS WRITTEN LIMITED WARRANTY OR ANY IMPLIED WARRANTY. SOME STATES AND PROVINCES DO NOT ALLOW THE EXCLUSION OR LIMITATION OF INCIDENTAL OR CONSEQUENTIAL DAMAGES, OR LIMITATIONS ON THE DURATION OF IMPLIED WARRANTIES, SO THESE LIMITATIONS OR EXCLUSIONS MAY NOT APPLY TO YOU. THIS WRITTEN WARRANTY GIVES YOU SPECIFIC LEGAL RIGHTS. YOU MAY ALSO HAVE OTHER RIGHTS THAT VARY FROM STATE TO STATE.

### If You Need Service

Keep your receipt, delivery slip, or some other appropriate payment record to establish the warranty period should service be required. If service is performed, it is in your best interest to obtain and keep all receipts. Service under this warranty must be obtained by contacting Electrolux at the addresses or phone numbers below.

This warranty only applies in the USA, Puerto Rico and Canada. In the USA and Puerto Rico, your appliance is warranted by Electrolux Major Appliances North America, a division of Electrolux Home Products, Inc. In Canada, your appliance is warranted by Electrolux Canada Corp. Electrolux authorizes no person to change or add to any obligations under this warranty. Obligations for service and parts under this warranty must be performed by Electrolux or an authorized service company. Product features or specifications as described or illustrated are subject to change without notice.

USA  
1-877-435-3287  
Electrolux Major Appliances North America  
10200 David Taylor Drive  
Charlotte, NC 28262

Canada  
1-800-265-8352  
Electrolux Canada Corp.  
5855 Terry Fox Way  
Mississauga, Ontario, Canada L5V 3E4